

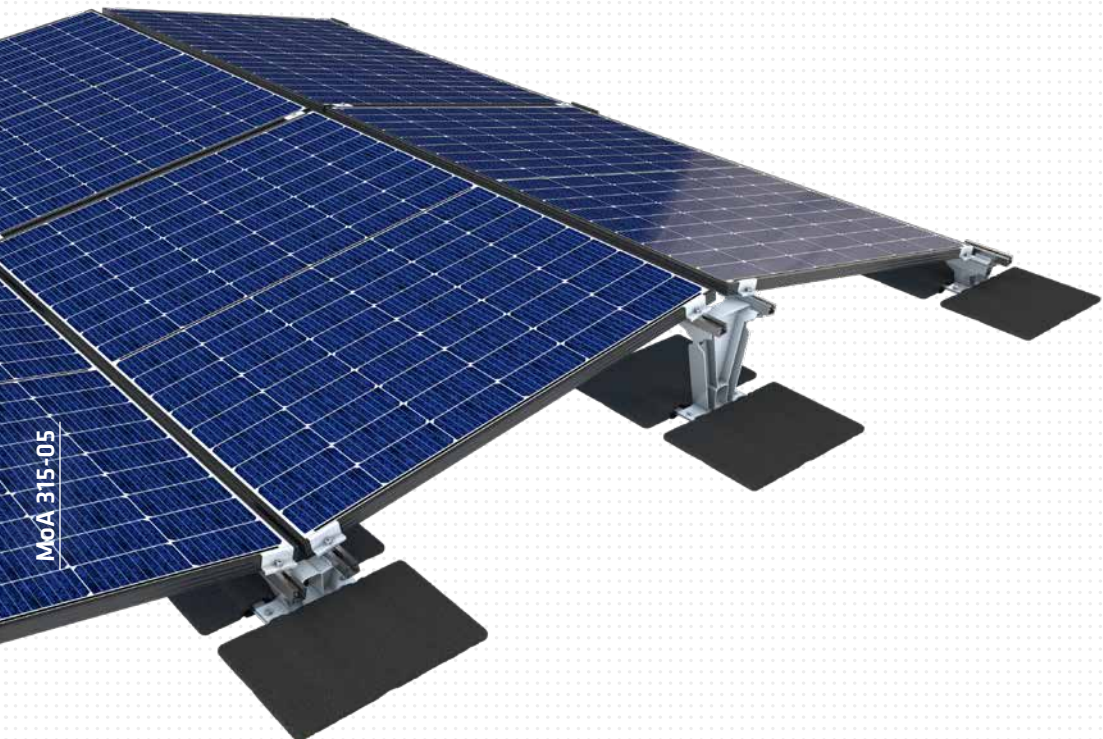

# ABS Base Fusion



## WICHTIGE INFORMATIONEN

### Hinweis zur Montage und Wartung von PV-Anlagen

- Vor der Montage ist eine exakte Planung der Anlage unter Berücksichtigung der statischen Anforderungen und Bedingungen des Installationsortes vorzunehmen.
- Soweit eine Montage auf einer gedämmten Fläche erfolgt sollte die Dämmung einer Druckbelastung von 70 kPa standhalten. Es muss jedoch immer eine projektspezifische Bewertung erfolgen.
- Die Installation darf nur von Personen durchgeführt werden, die über die entsprechende Fach- und Sachkunde verfügen.
- Vor der Installation ist sicherzustellen, dass alle Arbeitsschutz- und Unfallverhütungsvorschriften eingehalten werden. Dies betrifft insbesondere, aber nicht ausschließlich das Vorhalten einer ausreichenden Absturzsicherung.
- Es wird empfohlen, dass die bituminöse Abdichtungsbahn nicht älter als 1 Jahr ist.
- Die Dachabdichtung muss aus einer Abdichtungsbahn mit einer Vlieseinlage von min 250g/m<sup>2</sup> bestehen. Grundsätzlich ist eine zweilagige Abdichtung erforderlich.
- Nationale und örtliche Bauvorschriften, Normen und Umweltschutzbestimmungen sind unbedingt einzuhalten.
- Der Potentialausgleich zwischen den einzelnen Anlagenteilen ist nach den jeweiligen landesspezifischen Vorschriften durchzuführen.
- Die Einbindung der Anlage in den Blitzschutz ist durch eine entsprechend geschulte und ausgebildete Person vorzunehmen.
- Es ist stets die aktuellste Fassung der Montageanleitung zu verwenden und auf der Baustelle vorzuhalten.
- Es ist stets dafür Sorge zu tragen, dass die Anlage in einem technisch einwandfreien Zustand ist.
- Die Anlage muss regelmäßig und fachmännisch gewartet, kontrolliert und instandgehalten werden. Insbesondere ist eine regelmäßige Sichtkontrolle durchzuführen.
- Die aktuellen Vorgaben der Berufsgenossenschaften und Unfallversicherer sind einzuhalten.

## IMPORTANT INFORMATION

### Information on the installation and maintenance of PV systems

- Prior to installation, an exact plan of the system needs to be drawn up, taking into account the static requirements and conditions at the installation site.
- If installed on an insulated surface, the insulation should be able to withstand a pressure load of 70 kPa. However, a project-specific assessment must always be carried out.
- The installation may only be carried out by individuals who have acquired the appropriate technical knowledge and expertise.
- Prior to installation, steps must be taken to ensure that all the relevant health and safety regulations as well as the regulations pertaining to the prevention of accidents have been complied with. This concerns in particular, but not exclusively, the provision of an adequate fall protection system.
- It is recommended that the bituminous waterproofing membrane is not older than 1 year.
- The roof waterproofing must consist of a waterproofing membrane with a fleece layer of at least 250g/m<sup>2</sup>. A two-layer membrane is always required.
- It is essential to ensure that the local and national building regulations, standards and environmental protection regulations are observed.
- All the individual components of the system need to be electrically bonded in accordance with the regulations specific to the country in question.
- The system may only be integrated into the lightning conductor system by an appropriately trained and qualified individual.
- Care must be taken to ensure that only the very latest version of the Installation Manual is used. A copy must be kept at the construction site.
- Steps must be taken to ensure that the system is in a technically perfect condition.
- The system must be regularly serviced, checked and maintained by an expert. In particular, visual inspections need to be carried out on a regular basis.
- The latest specifications issued by the employers' liability insurance associations and accident insurers also need to be observed.

## Werkzeuge | Tools



## Sicherheitshinweise | Safety instructions



- DE** Montageanleitung beachten (1) und Sicherheitshinweise beachten (2).
- EN** Comply with the installation manual (1) and Comply with the safety instructions (2).
- FR** Respecter la notice de montage (1) and Respecter les consignes de sécurité (2).
- NL** Montagehandleiding in acht nemen (1) and Veiligheidsinstructies in acht nemen (2).
- BGR** Спазвайте инструкциите за монтаж (1) and Спазвайте инструкциите за безопасност (2).
- DK** Følg monteringsvejledningen (1) and Følg sikkerhedshenvisningerne (2).
- ET** Järgige paigaldusjuhendit (1) ja ohutusjuhiseid (2).
- FI** Noudata asennusohjeita (1) and Noudata turvallisuusohjeita (2).
- IT** Rispettare le istruzioni di montaggio (1) and Rispettare le istruzioni di sicurezza (2).
- PL** Przestrzegać zaleceń instrukcji montażu (1) and Przestrzegać zasad bezpieczeństwa (2).
- SK** Dodržujte návod na montáž (1) and Dodržujte bezpečnostné pokyny (2).
- SL** Sledite navodilom za namestitve (1) and Sledite varnostnim navodilom (2).
- ES** Observar las instrucciones de montaje (1) and Observar las indicaciones de seguridad (2).
- CS** Dodržujte návod k montáži (1) and Dodržujte bezpečnostní pokyny (2).
- HU** Vegye figyelembe az összeszerelési útmutatót (1) and Vegye figyelembe a biztonsági utasításokat (2).

Für eine ordnungsgemäße Montage ist eine Dokumentation des Einbaus zwingend erforderlich!  
For a proper installation, a complete documentation of assembly is absolutely necessary.

## Kontakte | Contact persons

**Vertrieb & Technische Beratung**  
Sales & Technical Support  
+49 (0) 28 32 - 972 81 - 0  
vertrieb@absturzschutz.de

**Schulung**  
Training  
+49 (0) 28 32 - 972 81 - 148  
schulung@absturzschutz.de

**Montagevorbereitung**  
Assembly  
+49 (0) 28 32 - 972 81 - 260  
service@absturzschutz.de

## Mustertypenschild | Sample label

	<b>ABS SAFETY GMBH</b> Kevelaer, Germany info@absturzschutz.de www.absturzschutz.de		
<b>Typ / Produktbezeichnung</b> Typ / Produktbezeichnung		<b>Chargennummer / Batch number</b> 	4
6 Normen / Standards 7 Max. Nutzer gleichzeitig 11 Modellnummer / Model number 14 150 kg	- - - - - -	8  0158  Z-14.9-668  DEKRA	9 10

# Montageschritte dokumentieren

Document assembly step



Dokumentation mit Bildern vervollständigen!  
Complete your documentation using pictures!

**Dokumentation  
ist Pflicht!**

Documentation is compulsory!

# Inhalt | Content

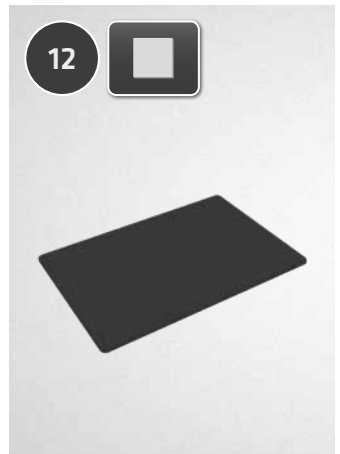
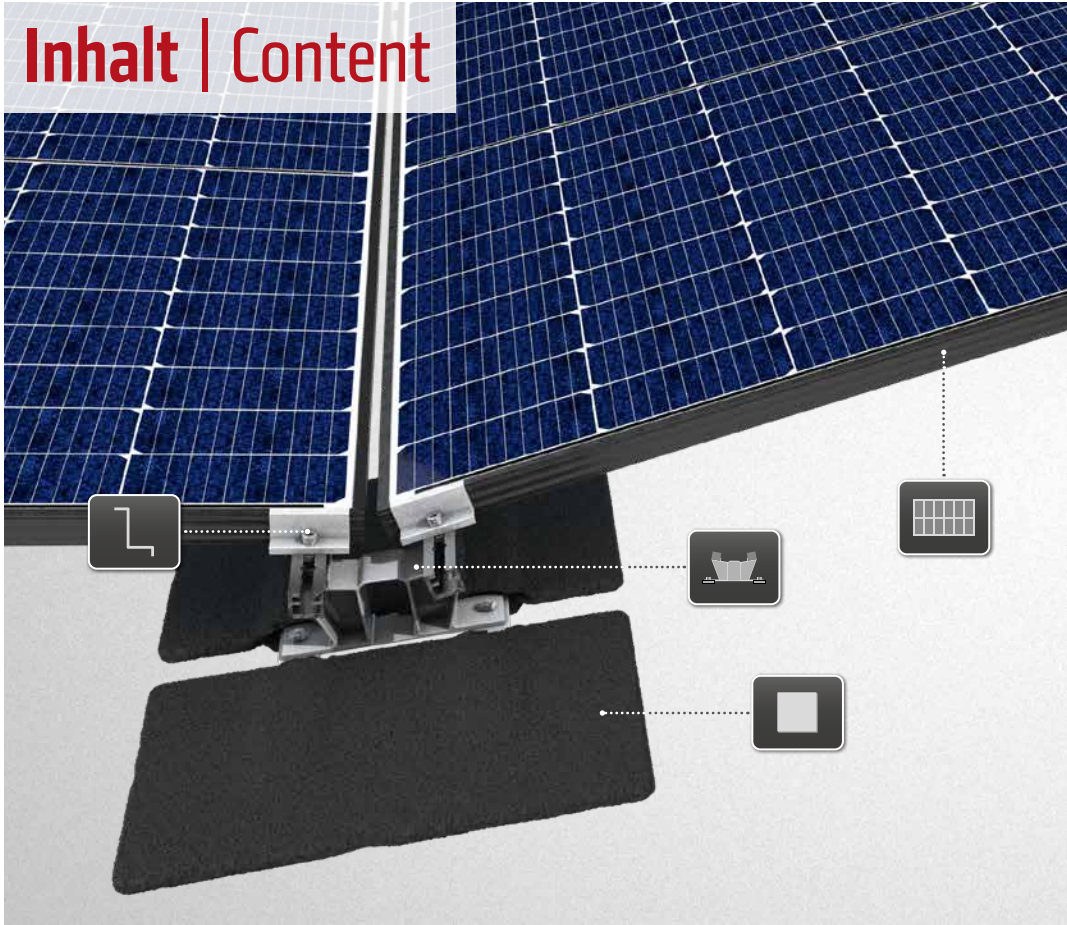

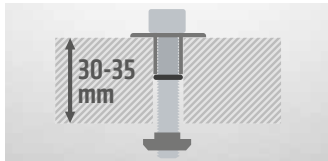
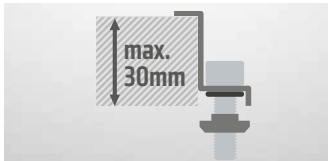
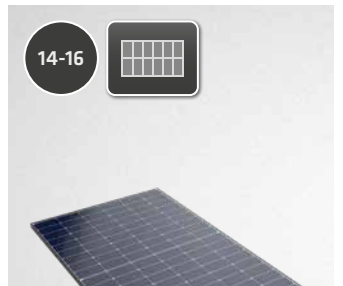
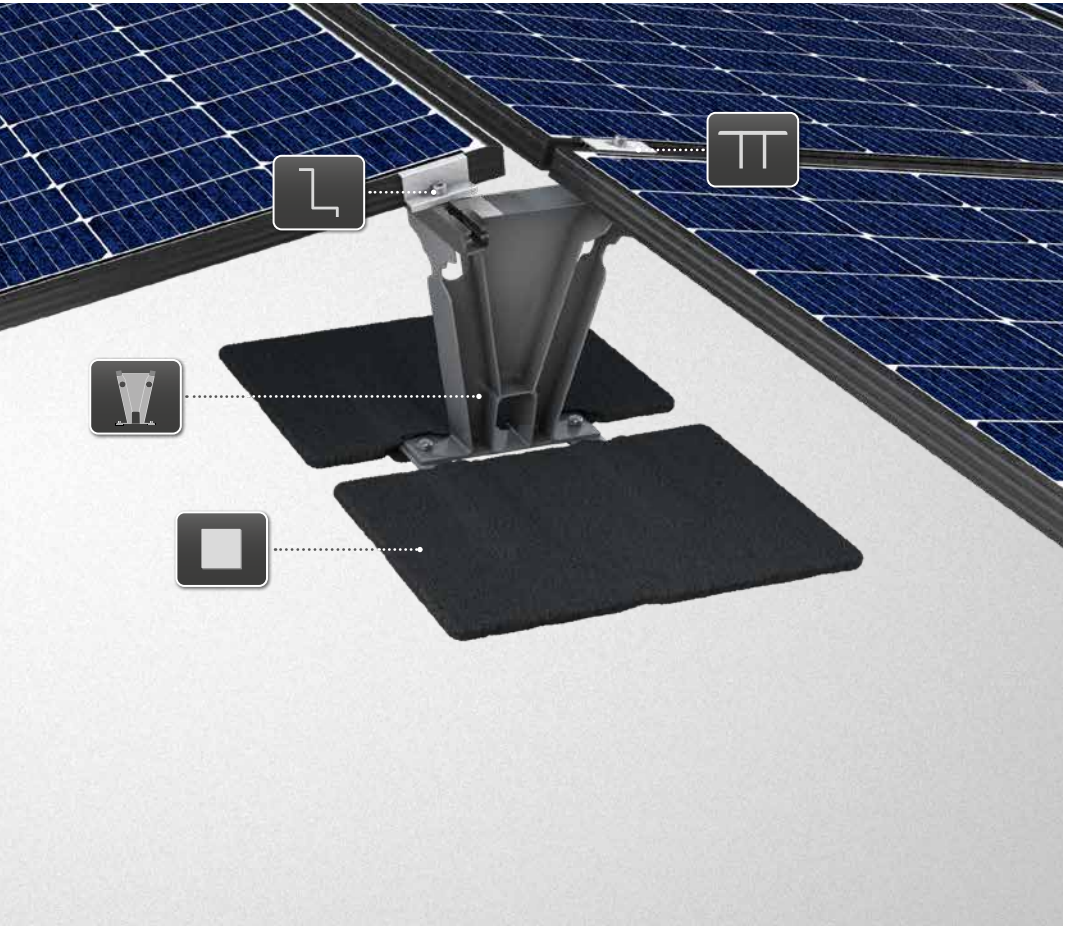

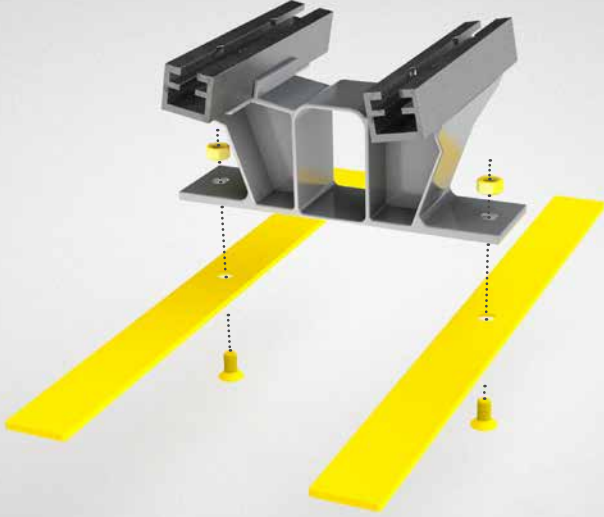

1/2

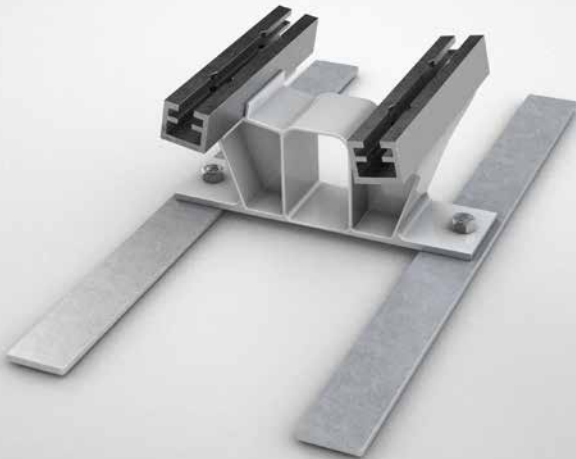

2/2





• Nm 13 | 20 Nm

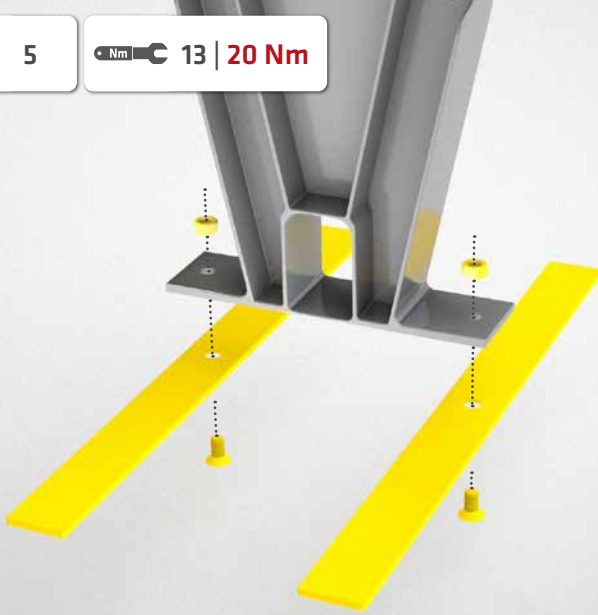

1/2



2/2

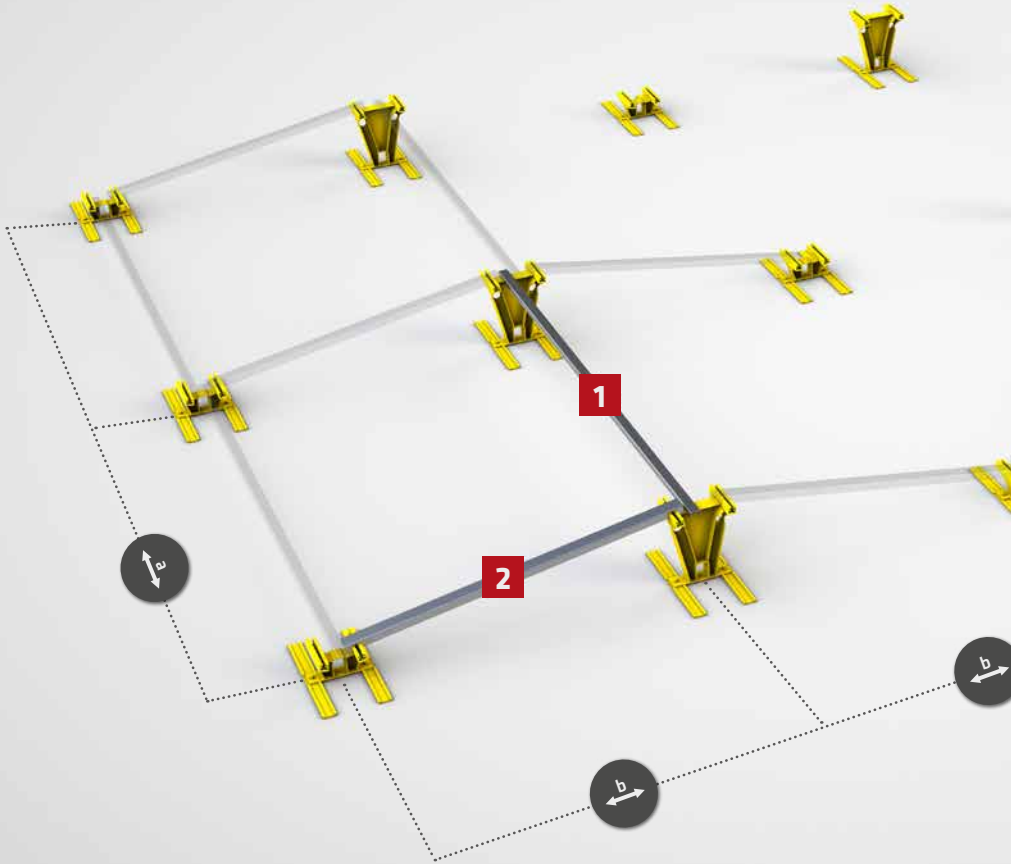

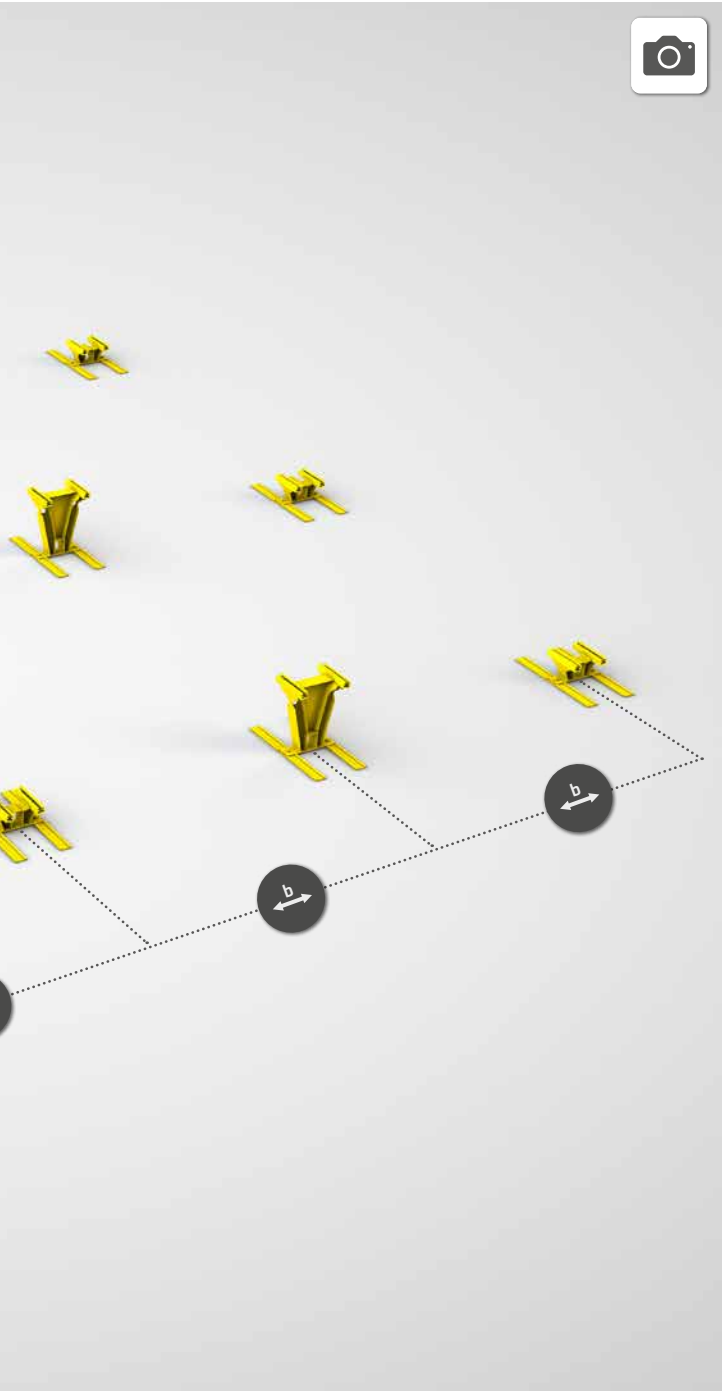

Optional

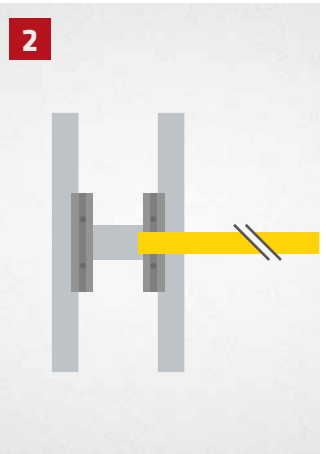
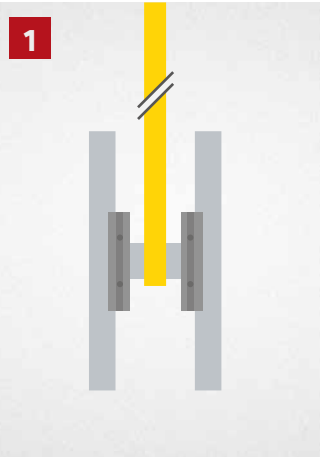

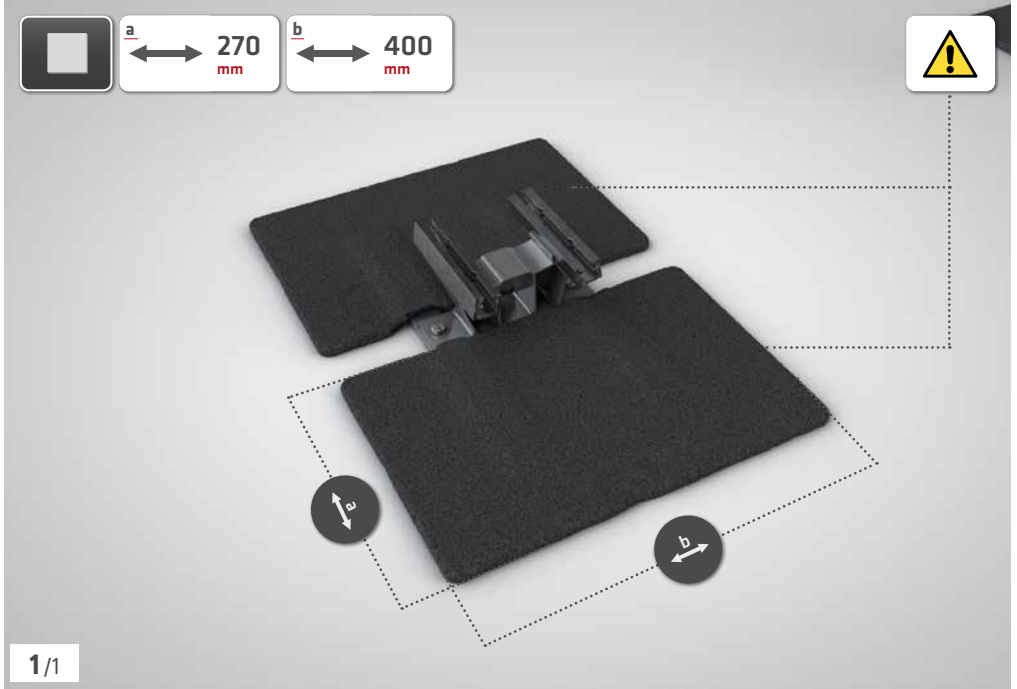

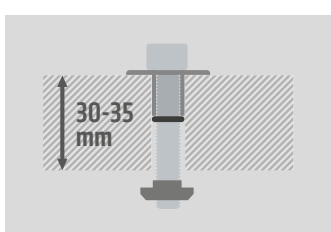
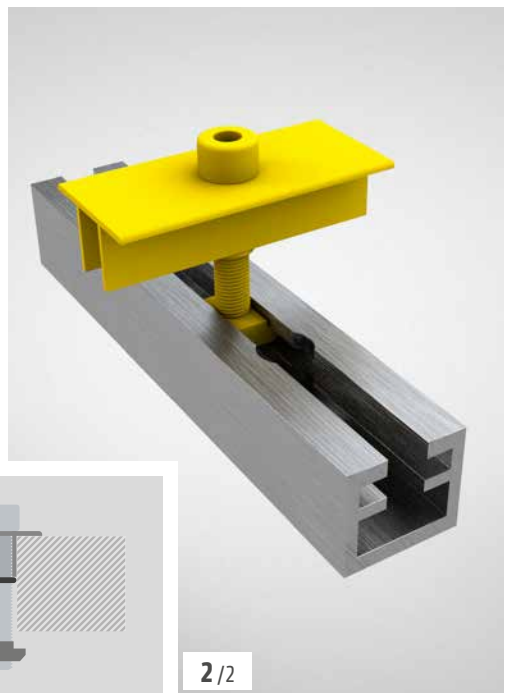
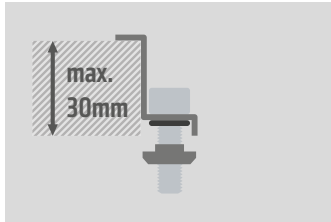
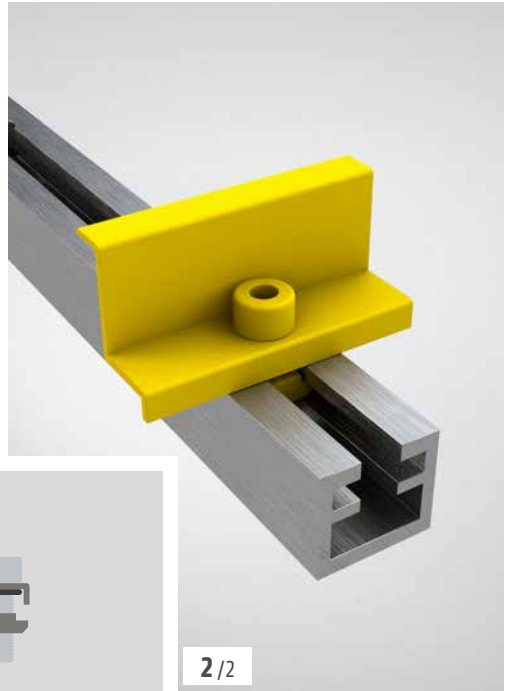

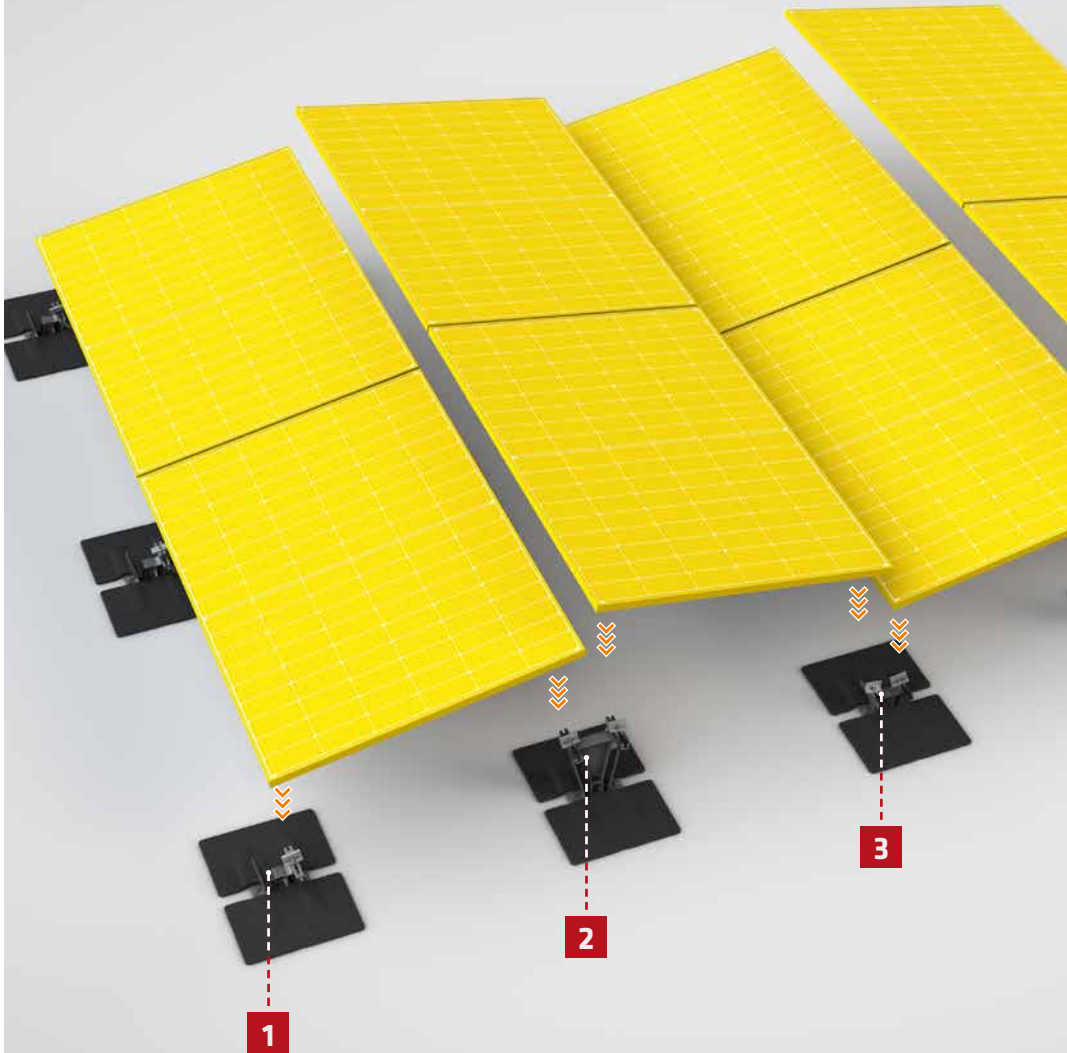

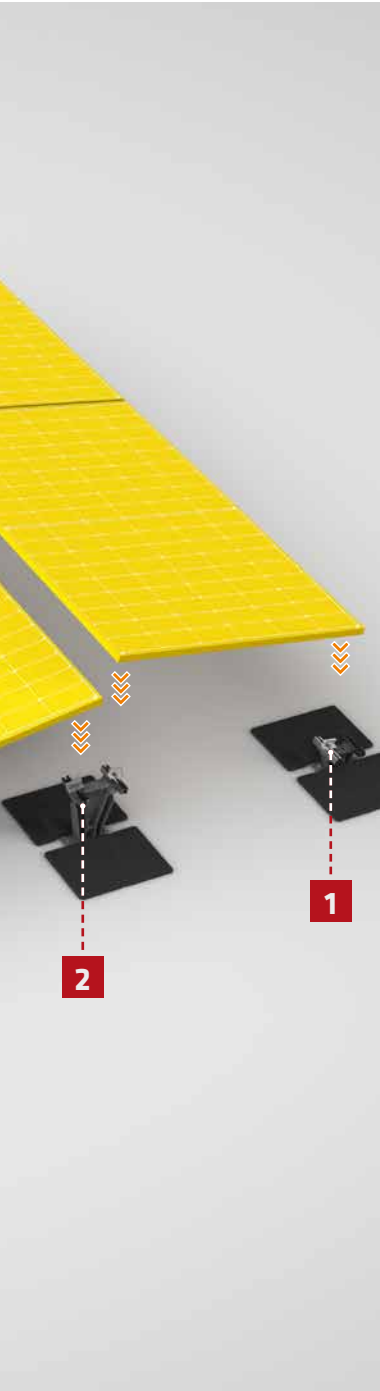

Optional



a  
49  
mm

1

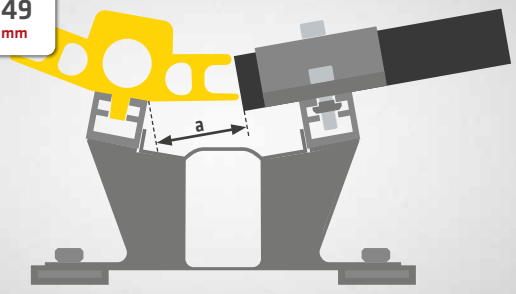

b  
36,5  
mm

2

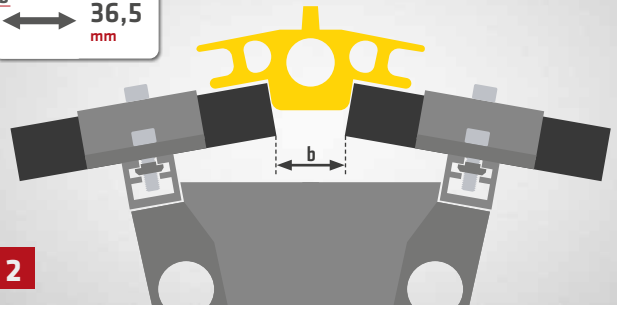

c  
9  
mm

3

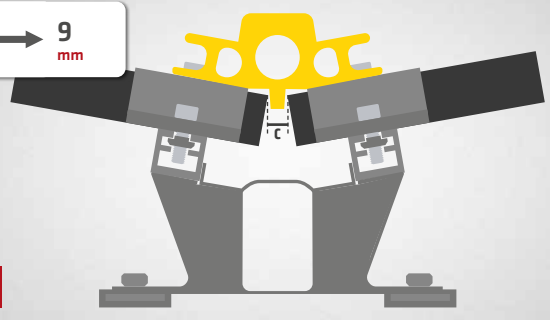

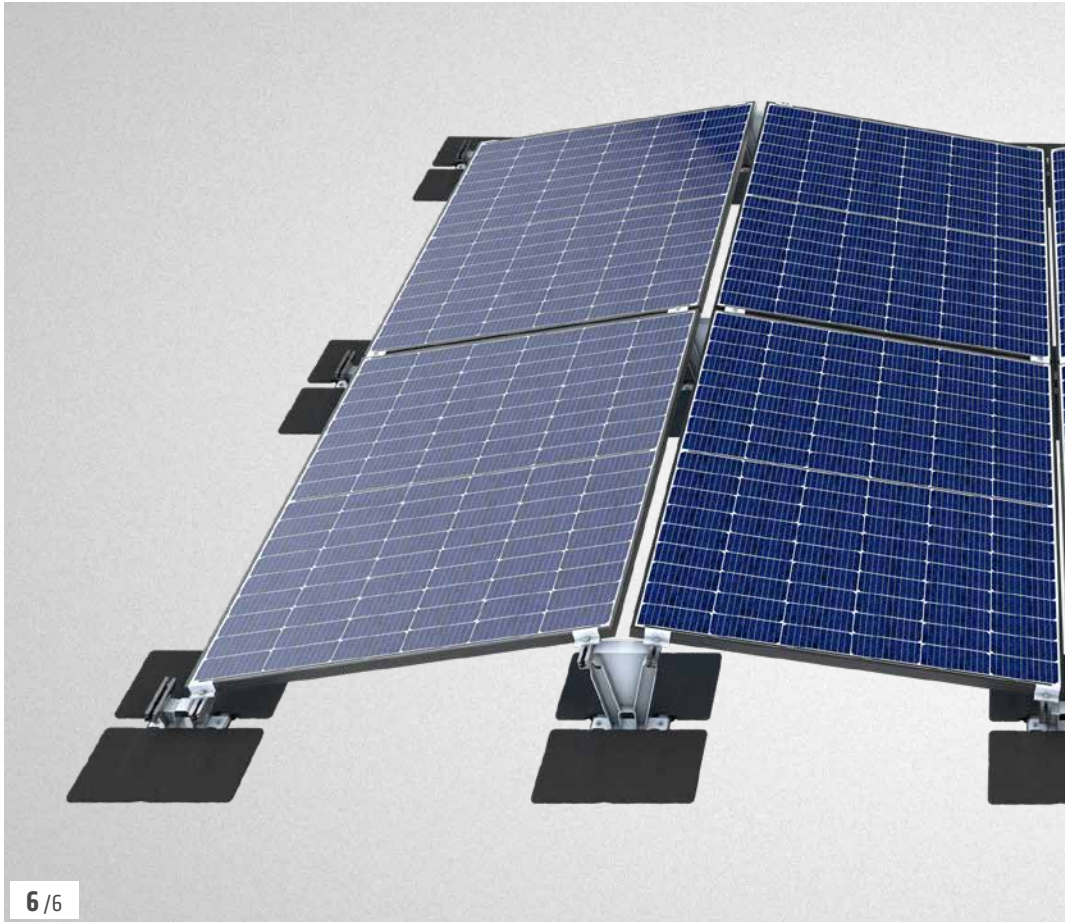
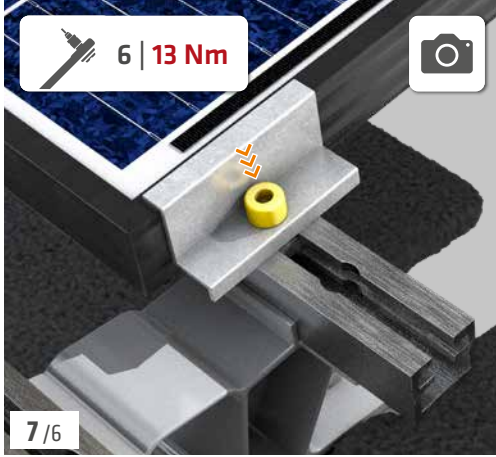



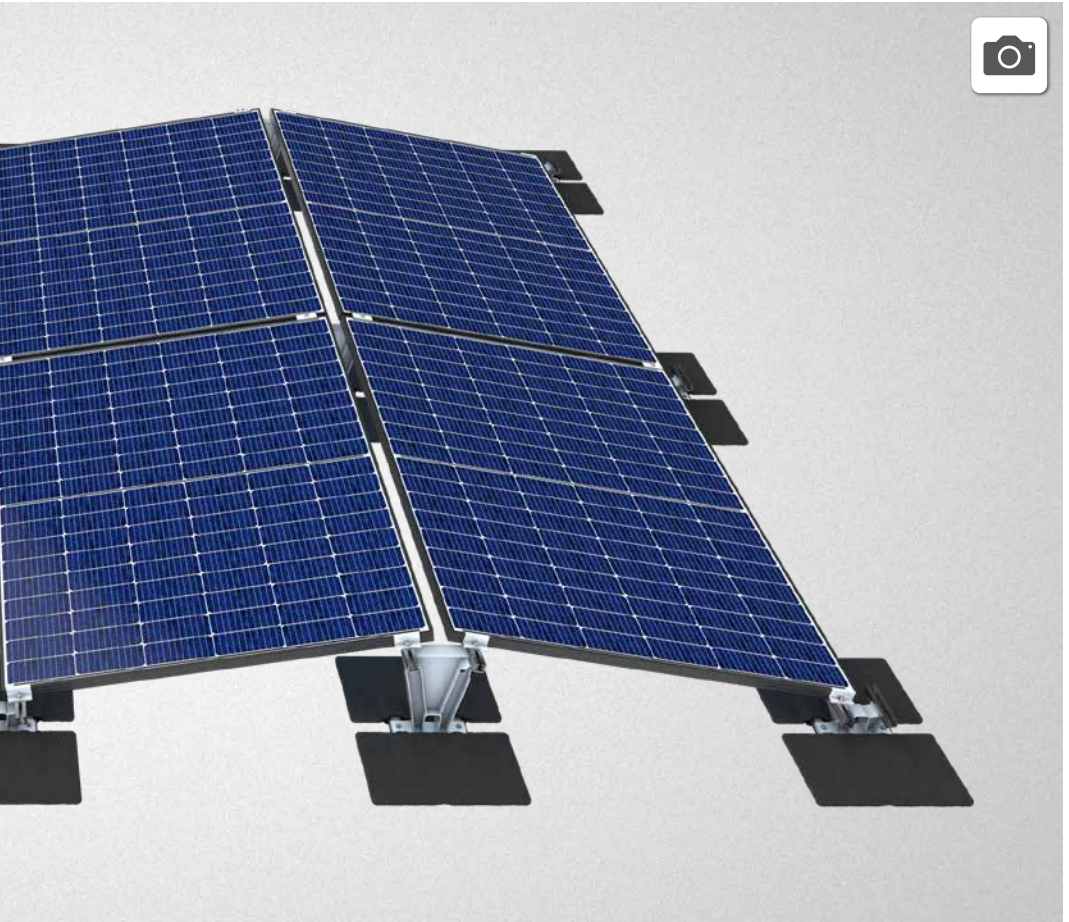
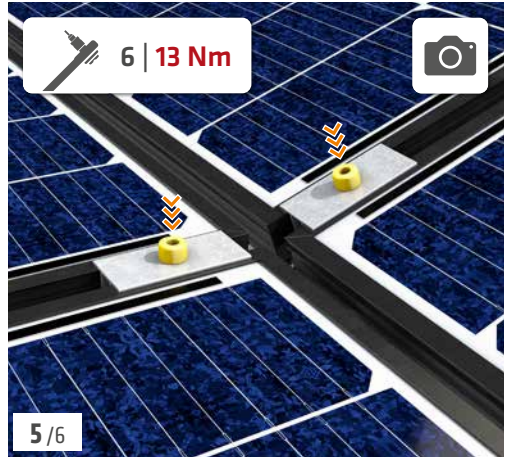
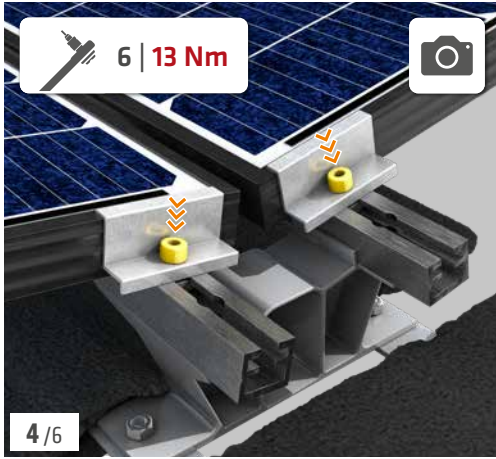

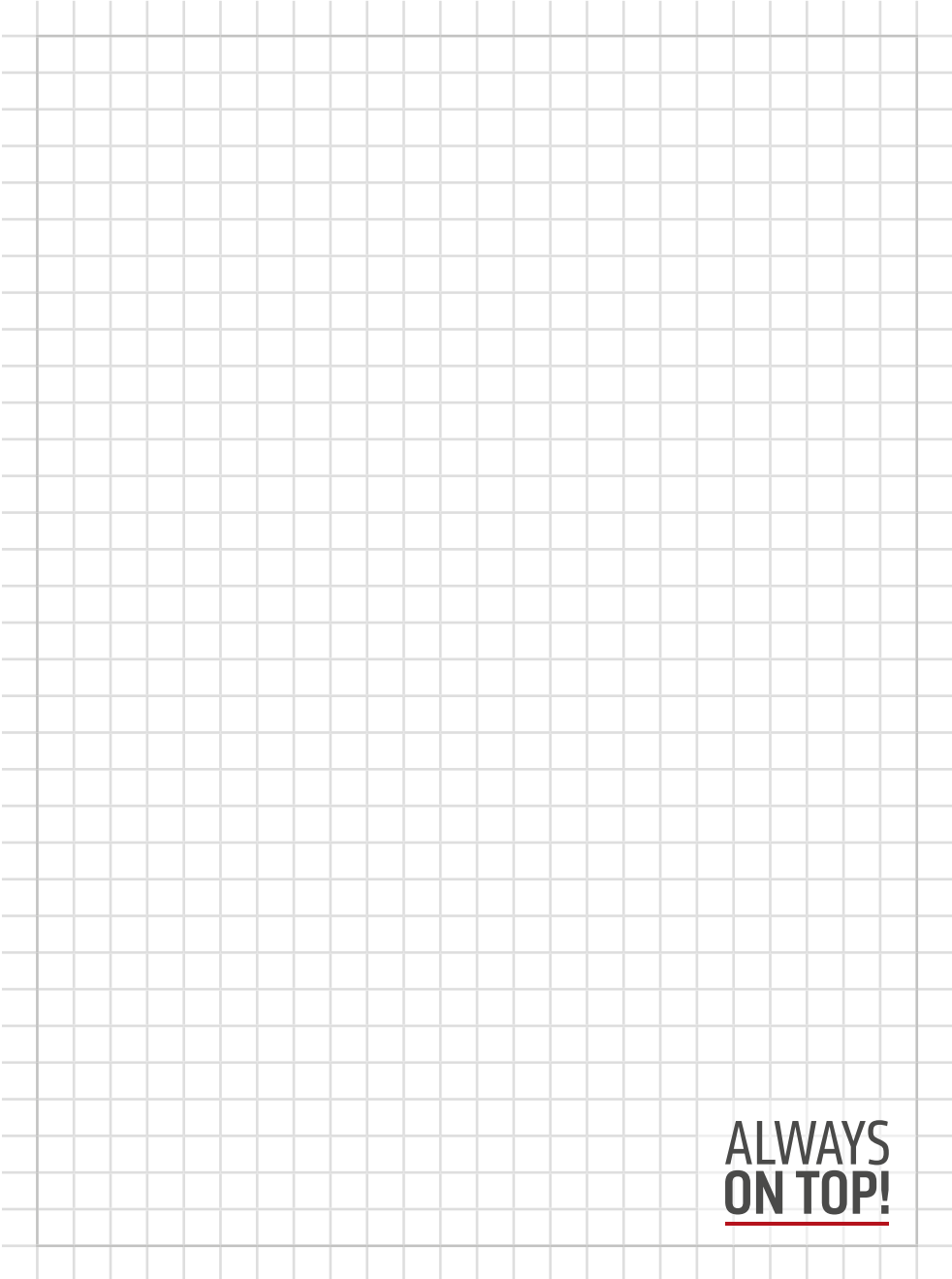

**ALWAYS  
ON TOP!**

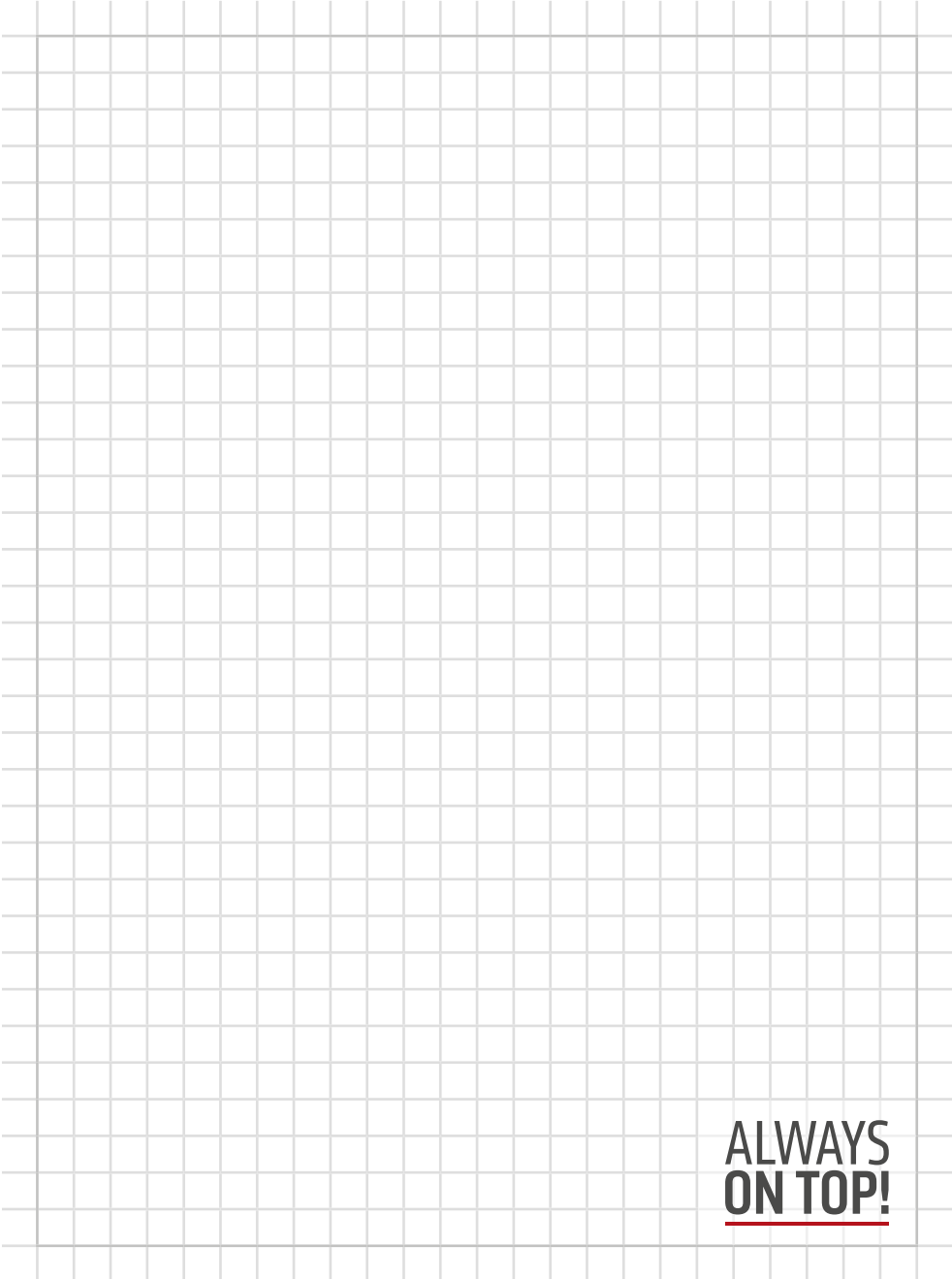

**ALWAYS  
ON TOP!**

# ALWAYS ON TOP!

## ABS Safety GmbH

Gewerbering 3  
D-47623 Kevelaer  
Germany

Tel.: +49 28 32 972 81 - 0  
Fax: +49 28 32 972 81 - 285

info@absturzschutz.de

 [www.absturzschutz.de](http://www.absturzschutz.de)

 [.de/en](http://.de/en)

 [.de/fr](http://.de/fr)

 [.de/nl](http://.de/nl)



[instagram.com/abssafety](https://www.instagram.com/abssafety)



[youtube.com/abssafetygmbh](https://www.youtube.com/abssafetygmbh)



[facebook.com/ABS.Safety](https://www.facebook.com/ABS.Safety)



[linkedin.com/company/abs-safety-gmbh](https://www.linkedin.com/company/abs-safety-gmbh)



[xing.com/pages/abssafetygmbh](https://www.xing.com/pages/abssafetygmbh)